

Nulok Global UK Ltd

15 Duke Street
Ballymena
Co. Antrim
BT43 6BL

Tel: 033 0123 4440

e-mail: info@nulokroofing.com

website: www.nulokroofing.com



Agrément Certificate

21/5922

Product Sheet 1

NULOK

NULOK ROOFING SYSTEM

This Agrément Certificate Product Sheet⁽¹⁾ relates to the Nulok Roofing System, for use as a steel frame roofing system to accommodate tiles, solar voltaic tiles, slates or generic tiles in conventional pitched roofs with a pitch ranging between 10° and 70°. The system comprises steel battens, link channels and stainless steel clips and can be installed over timber or steel roof structures.

(1) Hereinafter referred to as 'Certificate'.

CERTIFICATION INCLUDES:

- factors relating to compliance with Building Regulations where applicable
- factors relating to additional non-regulatory information where applicable
- independently verified technical specification
- assessment criteria and technical investigations
- design considerations
- installation guidance
- regular surveillance of production[†]
- formal three-yearly review.[†]

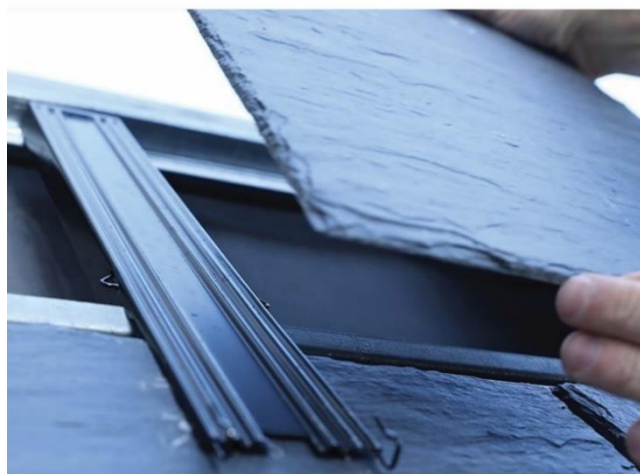

KEY FACTORS ASSESSED

Structural performance — the system can adequately retain roofing tiles and transmit permanent and variable actions to the supporting structure (see section 6).

Performance in relation to fire — the battens and clips are classified as A1 in accordance with BS EN 13501-1 : 2018.

The Certificate holder has not declared a reaction to fire classification BS EN 13501-1 : 2018 for the Nulok link channel (see section 7).

Durability — the system will have a service life in excess of 25 years (see section 10).

The BBA has awarded this Certificate to the company named above for the system described herein. This system has been assessed by the BBA as being fit for its intended use provided it is installed, used and maintained as set out in this Certificate.

On behalf of the British Board of Agrément

Date of First issue: 19 July 2021

Hardy Giesler
Chief Executive Officer

This Certificate was amended on 22 May 2024 as part of a transition of The BBA Agrément Certificate scheme delivered under the BBA's ISO/IEC 17020 accreditation. This Certificate was issued originally under accreditation to ISO/IEC 17065. Sections marked with the symbol † are not issued under accreditation. Full conversion to the ISO/IEC 17020 format will take place at the next Certificate review. The BBA is a UKAS accredited Inspection Body (No.4345). Readers MUST check the validity of this Agrément Certificate by either referring to the BBA website or contacting the BBA directly. Any photographs are for illustrative purposes only, do not constitute advice and must not be relied upon.

British Board of Agrément

Bucknalls Lane
Watford
Herts WD25 9BA

©2021

tel: 01923 665300
clientservices@bbacerts.co.uk
www.bbacerts.co.uk

Regulations

In the opinion of the BBA, the Nulok Roofing System, if installed, used and maintained in accordance with this Certificate, can satisfy or contribute to satisfying the relevant requirements of the following Building Regulations (the presence of a UK map indicates that the subject is related to the Building Regulations in the region or regions of the UK depicted):



The Building Regulations 2010 (England and Wales) (as amended)

Requirement: Comment:	A1	Loading The system will have sufficient strength and stiffness to sustain and transmit the design loads. See section 6 of this Certificate.
Requirement: Comment:	B4(2)	External fire spread The system can contribute to satisfying this Requirement. See section 7.1 of this Certificate.
Regulation: Comment:	7(1)	Materials and workmanship The system is acceptable. See section 10 and the <i>Installation</i> part of this Certificate.



The Building (Scotland) Regulations 2004 (as amended)

Regulation: Comment:	8(1)(2)	Durability, workmanship and fitness of materials The system can contribute to a construction satisfying the requirements of this Regulation. See sections 9 and 10 and the <i>Installation</i> part of this Certificate.
Regulation: Standard: Comment:	9 1.1(a)(b)	Building standards applicable to construction Structure The system has sufficient strength and stiffness to sustain and transmit the design loads, with reference to clause 1.1.1 ⁽¹⁾⁽²⁾ of this Standard. See section 6 of this Certificate.
Standard: Comment:	2.8	Spread from neighbouring buildings The system can contribute to satisfying this Standard, with reference to clause 2.8.1 ⁽¹⁾⁽²⁾ . See section 7.1 of this Certificate.



The Building Regulations (Northern Ireland) 2012 (as amended)

Regulation: Comment:	23(a)(i) (iii)(b)(i)	Fitness of materials and workmanship The system is acceptable. See section 10 and the <i>Installation</i> part of this Certificate.
Regulation: Comment:	30	Stability The system has sufficient strength and stiffness to sustain and transmit the design loads to the supportive structure without excessive deflection or deformation. See section 6 of this Certificate.
Regulation: Comment:	36(b)	External fire spread The system can contribute to satisfying this Regulation. See section 7.1 of this Certificate.

Construction (Design and Management) Regulations 2015

Construction (Design and Management) Regulations (Northern Ireland) 2016

Information in this Certificate may assist the client, designer (including Principal Designer) and contractor (including Principal Contractor) to address their obligations under these Regulations.

See sections: 3 *Delivery and site handling* (3.1), 9 *Maintenance* (9.2 and 9.3) and 12 *General* (12.6) of this Certificate.

Technical Specification

1 Description

1.1 The Nulok Roofing System comprises galvanized steel battens and link channels, and stainless steel clips (see Figure 1), for the mounting and retention of roofing tiles and slates on pitched roofs. The system (see Figure 2) is an alternative to conventional timber battens and tile fixings.

1.2 The system components have the following specifications:

- Nulok Metal Battens — hot-dipped galvanized mild steel; DX51D+ Z275 to BS EN 10346 : 2015 (available in lengths up to 5400 mm)
- Nulok Link Channels — S350GD + Z140 galvanized steel to BS EN 10346 : 2015, with a 22 micron thick black electrophoretic coating, applied after cutting and pressing
- Nulok Stainless Steel Spring Clips – 1.6 mm diameter, cold-drawn, 1.4310 stainless steel to BS EN 10270-3 : 2011.

Figure 1 Link channel and stainless steel clips attached to batten

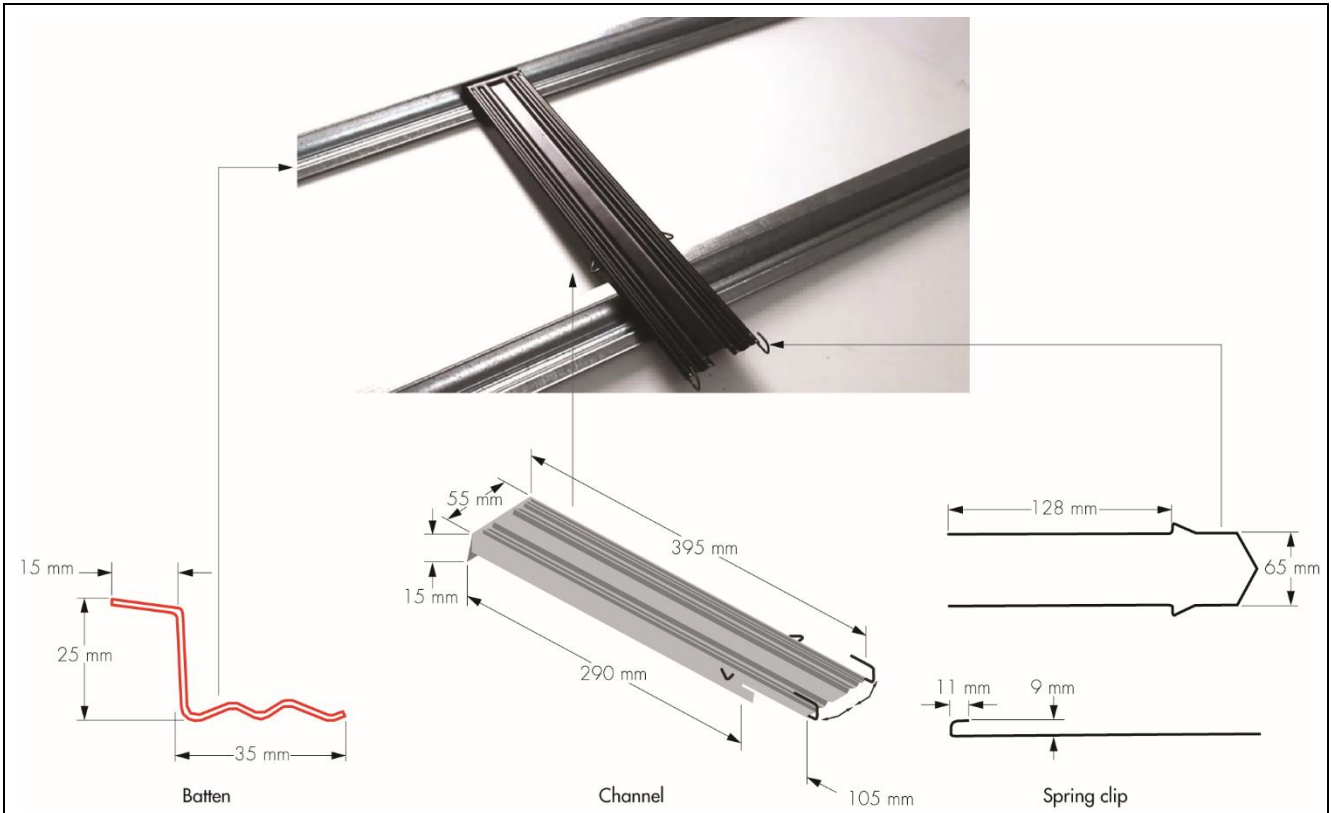

1.3 Ancillary items for use with the system, but outside the scope of this Certificate, are:

- roof tiles or slates
- solar inserts
- fixings – typically nail gun galvanized nail, with a minimum head diameter of 6.45 mm and a shank diameter of 2.80 mm with an overall nail length of 51.0 mm, alternatively 5.5 x 50 mm hex-drive screws (for relevant information please refer to Certificate holder's installation manual)
- sealants
- flashings
- guttering
- membranes
- underlays
- sheathing or sarking boards.

Figure 2 Typical Nulok roof build-up

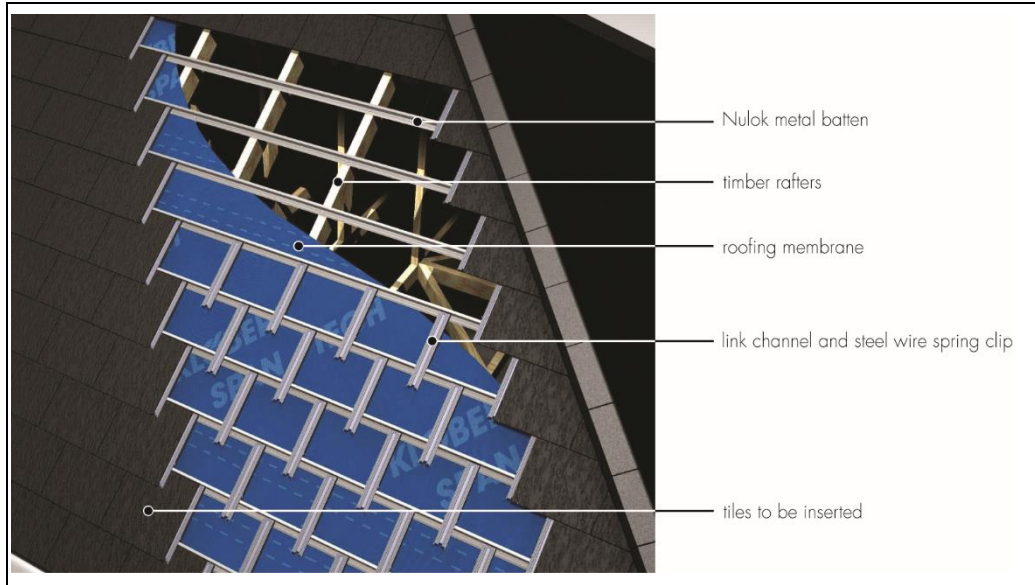

2 Manufacture

2.1 The system components are manufactured from steel coil using conventional metal-working techniques. The link channels are further processed with the addition of a paint coating.

2.2 As part of the assessment and ongoing surveillance of product quality, the BBA has:

- agreed with the manufacturer the quality control procedures and product testing to be undertaken
- assessed and agreed the quality control operated over batches of incoming materials
- monitored the production process and verified that it is in accordance with the documented process
- evaluated the process for management of nonconformities
- checked that equipment has been properly tested and calibrated
- undertaken to carry out the above measures on a regular basis through a surveillance process, to verify that the specifications and quality control operated by the manufacturer are being maintained.

3 Delivery and site handling

3.1 The system components are delivered to site with all sufficient parts for construction. The metal battens are delivered to site in bundles of nine, and the link channels and stainless-steel clips are packaged in boxes of 84.

3.2 The components should be stored on a dry, level base, under cover and away from the possibility of damage.

3.3 All components are labelled with the manufacturer's name and address, product details, batch number, size, quantity and weight.

Assessment and Technical Investigations

The following is a summary of the assessment and technical investigations carried out on the Nulok Roofing System.

Design Considerations

4 Use

4.1 The Nulok Roofing System is satisfactory for use on conventional, pitched, timber or steel roofs with a finished rafter pitch between 10° and 70°. It is essential that such roofs are designed and constructed to incorporate the normal precautions to prevent moisture penetration and the formation of condensation (eg by adequate ventilation).

4.2 Roofs incorporating the system should be designed and constructed in accordance with the relevant recommendations of BS 5534 : 2014 and BS 8000-6 : 2013. In particular, the designer should follow the recommendations of clauses 5.2, 5.4, 5.5 and 5.9 of BS 5534 : 2014 on structural stability; rain and snow resistance; roof pitch head-laps and side-laps; and control of condensation, respectively. In addition, the designer must select a construction appropriate to its location, paying due attention to design detailing, workmanship and materials to be used. Typical assembly detail is shown in Figure 3.

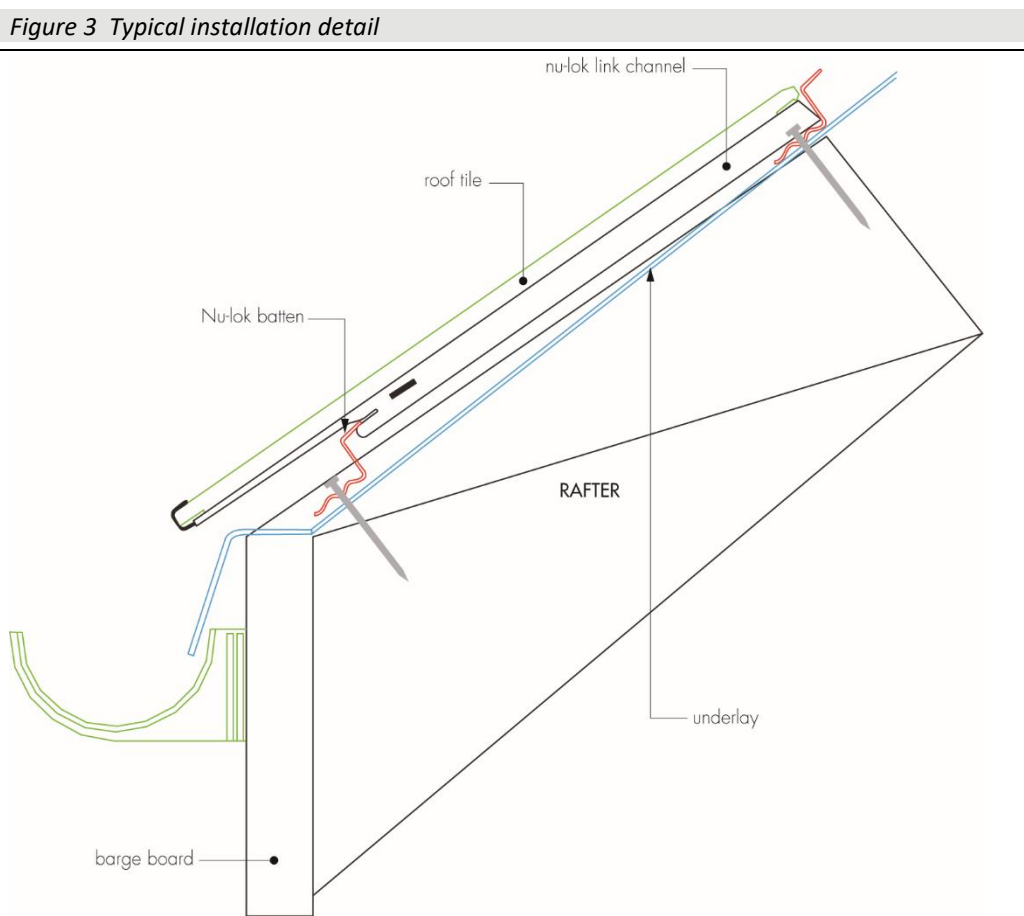

4.3 To achieve full fixity, roof tiles or slates used with the system must be of an adequate thickness (6.5 mm thick at the retained edge) to fill the return on the clip, and 400 mm long. Tiles or slates must comply with the requirements of the appropriate product standards, including:

- BS 5534 : 2014
- BS EN 490 : 2011
- BS EN 492 : 2012
- BS EN 1304 : 2013
- BS EN 12326-1 : 2014.

4.4 In general, link channels are spaced to provide one channel and clip per tile or slate, with additional link channels and clips provided at the roof edge or hips or valleys to support the edges of the tile or slate.

4.5 The system is also satisfactory for use for the retention of solar panels, provided that they are designed to be retained by their bottom edge and are of an adequate thickness to fit the stainless steel clips. The Certificate holder can advise on compatible products and detailing.

5 Practicability of installation

The system is designed to be installed by competent general contractors experienced with this type of system.

6 Structural performance



6.1 The Nulok Roofing System, when used in conjunction with appropriate roof tiles or slates, has adequate strength and stiffness to sustain the specified design wind loads shown in Table 1 of this Certificate. The designer must ensure that the specified roof construction and the fixings to other structural elements can resist the appropriate positive and negative design load combinations as per BS EN 1990 : 2002 and its UK National Annex.

Spacing ⁽¹⁾	Maximum design wind resistance (negative) (kN·m ⁻²)
310 mm	1.5 ⁽²⁾

- (1) Nulok DX51D+ Z275 galvanized steel battens, screwed down to the rafters, at 600 mm centres with 5.5 mm x 50 mm hex drive screws, and fitted at 310 mm spacings using a 300 x 400 mm standard tile size.
- (2) The resistance values are calculated based on characteristic resistance divided by a partial material factor of 2, based on the mode of failure.

6.2 The system has adequate resistance to the uniformly distributed positive loads (wind, snow) likely to be encountered in the UK. Where high local snow loads may occur, attention in design must be paid to the loads on roofs from snow drifting against vertical obstructions and in valleys.

6.3 The maximum spacing of the supporting rafters must be no greater than 600 mm centre-to-centre. The adequacy of the supporting rafters must be ascertained by a suitably qualified and experienced engineer

6.4 The system has adequate strength and stiffness to resist to damage during site handling and installation using conventional roofing methods.

7 Performance in relation to fire



7.1 The battens and clips have the classification A1 in accordance with BS EN 13501-1 : 2018, The Certificate holder has not declared a reaction to fire classification to BS EN 13501-1 : 2018 for the Nulok link channel.

7.2 The reaction to fire classification of the entire roof construction will depend largely on the type of roof tiles or slates used, and must be determined in accordance with the requirements of the documents supporting the national Building Regulations.

8 Weathertightness

8.1 The combination of roof tile or slate, and roofing underlay used in conjunction with the Nulok Roofing System will determine the weathertightness of the roof and its suitability for the intended exposure conditions.

8.2 The system has adequate stiffness to retain roofing tiles and slates without undue deflection that would compromise the weathertightness of the roof.

9 Maintenance



9.1 The system should be inspected regularly to check for accidental damage to the roof and for any build-up of dirt and debris. Damage must be repaired, and accumulated dirt and debris removed. The frequency of inspections will depend on the environment and use of the building.

9.2 Care is required when carrying out maintenance or any works on tiled roofs, and the recommendations contained in BS 5534 : 2014, clause 6.13 *Installation, repairs and maintenance* and BS 8000-0 : 2014, clause 6.14 *Workmanship, repairs and maintenance*, BS 8000-0 : 2014 and BS 8000-6 : 2013 section 11 *Safety and general precautions* must be followed.

9.3 Precautions should be taken to prevent danger to the public from falling broken or displaced tiles.

10 Durability



When installed in accordance with the requirements of this Certificate and the Certificate holder's installation manual, the Nulok Roofing System has a service life in excess of 25 years.

11 Reuse and recyclability

All of the Nulok Roofing System components can be recycled.

Installation

12 General

12.1 The product is installed in accordance with the Certificate holder's instructions, the relevant recommendations of BS 5534 : 2014, BS 8000-0 : 2014 and BS 8000-6 : 2013, and this Certificate, using conventional roof tiling techniques.

12.2 Timber roof frames must be designed and constructed in accordance with PD 6693-1 : 2019 and BS EN 1995-1-1 : 2004 and its UK National Annex, and preservative-treated in accordance with BS EN 351-1 : 2007.

12.3 Steel roof frames must be designed and constructed in accordance with BS EN 1993-1-1 : 2005 and BS EN 1993-1-3 : 2006 and their UK National Annexes.

12.4 Ventilation for roof and batten space should be provided in accordance with the requirements of BS 5250 : 2011.

12.5 To prevent electro-chemical corrosion of the metal components within the system, direct contact with copper or its alloys should be avoided, and run-off from adjacent copper roofs must not drain onto the installation.

12.6 Nulok Metal Battens can be cut with an angle grinder, hand-held metal shears or hacksaw.

12.7 Architectural hardware such as roof windows, solar panels, slate vents and vent pipes may be used with the system provided correct detailing is employed. The Certificate holder can provide advice on the correct detailing if required.

13 Procedure

13.1 The underlay should be fixed in accordance with the manufacturer's instructions, ensuring that it overhangs the fascia sufficiently to allow rainwater to drain into the gutter. This may require the use of an eaves tray.

13.2 A tilting fillet is installed behind the fascia board line. The top of the tilting fillet should be flush with the rear top edge of the fascia.

13.3 The Nulok Link Channels and Nulok Stainless Steel Spring Clips are assembled at ground level.

13.4 Nulok Metal Battens are fastened to the rafters (maximum span 600 mm) using the appropriate fixings for the timber or steel rafters. Battens must be secured to at least two rafters and should be trimmed to fit flush with the edge rafter. Where a laddered-barge is used, the battens must finish flush with the edge of the ladder. Where a longer batten length is required, individual battens may be butted together over a rafter. It is prudent to stagger batten joints across different rafters as work progresses up the roof.

13.5 Starting at eaves level, a row of Nulok Link Channels are slotted into position at 400 mm centres (or nearer, as appropriate to the width of the roof tile) across the roof. The channels are fixed by clipping them into the Nulok Metal Battens, above and below (see Figure 4). The channels are locked into position between the metal battens. The lower section of each link channel extends over the head of the tile below, retaining it in position.

13.6 As installation progresses, the two stainless steel clips protruding from the link channels are used to retain and secure the tail of the next row of tiles. Each row of tiles must be installed before proceeding to install the link channels on the next row up.

13.7 Ridge, verge, hip and valley details should be completed using Nulok Stainless Steel Spring Clips in accordance with the Certificate holder's instructions.

13.8 The verge should be completed using conventional cement mortar or approved proprietary systems, fixed in accordance with the manufacturer's instructions.

13.9 Where flashing is required, the cover flashing method should be used. Use of soakers is not permitted without metal separation.

13.10 Where the system is to be used on an existing roof structure, the recommendations contained in BS 5534 : 2014 and BS 8000-0 : 2014, should be followed.

Figure 4 Basic installation overview

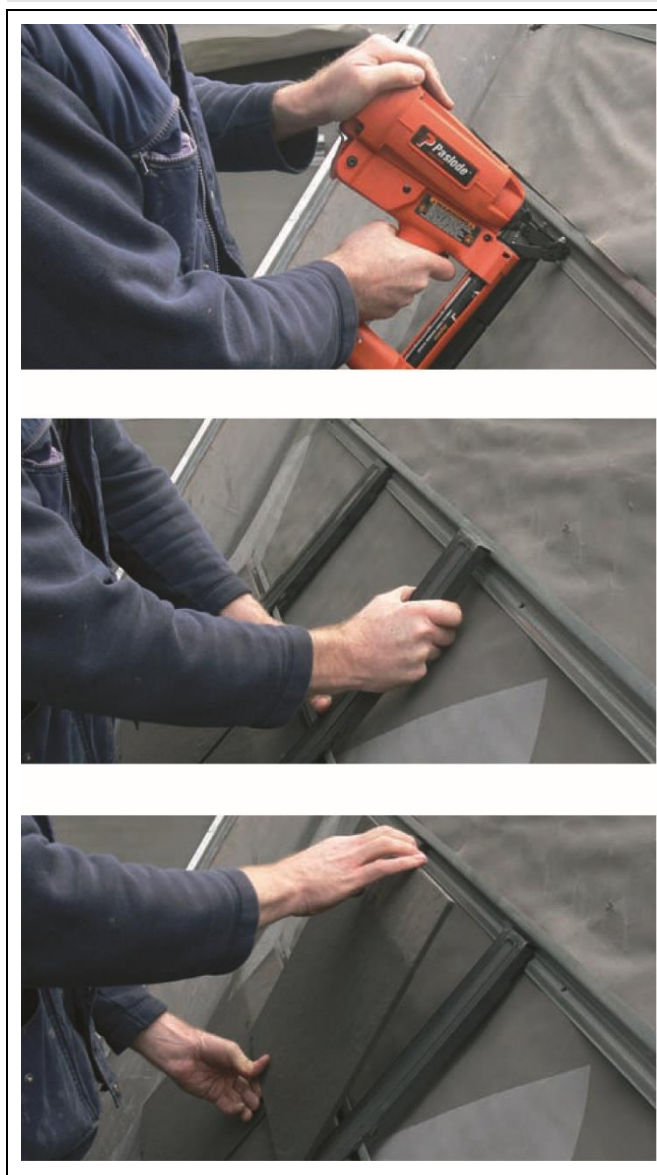

14 Tests

Tests were carried out and the results assessed to determine:

- resistance to dynamic wind suction
- resistance to dead and imposed (snow) loading
- scratching resistance
- resistance to corrosion.

15 Investigations

15.1 The manufacturing process was evaluated, including the methods adopted for quality control, and details were obtained of the quality and composition of the materials used.

15.2 The Certificate holder's technical literature was examined.

15.3 An assessment was made of:

- reaction to fire
- practicability of installation
- condensation risk.

15.4 Existing information relating to the durability of the systems and compatibility of materials in contact, was examined.

Bibliography

BS 5250 : 2011 + A1 : 2016 *Code of practice for control of condensation in buildings*

BS 5534 : 2014 + A2 : 2018 *Slating and tiling for pitched roofs and vertical cladding – Code of practice*

BS 8000-0 : 2014 *Workmanship on construction sites – Introduction and general principles*

BS 8000-6 : 2013 *Workmanship on building sites – Code of practice for slating and tiling of roofs and claddings*

BS EN 351-1 : 2007 *Durability of wood and wood-based products – Preservative-treated solid wood – Classification of preservative penetration and retention*

BS EN 490 : 2011 + A1 : 2017 *Concrete roofing tiles and fittings for roof covering and wall cladding – Product specifications*

BS EN 492 : 2012 + A2 : 2018 *Fibre-cement slates and fittings – Product specification and test methods*

BS EN 1304 : 2013 *Clay roofing tiles and fittings – Product definitions and specifications*

BS EN 1993-1-1 : 2005 + A1 : 2014 *Eurocode 3 – Design of steel structures – General rules and rules for buildings*

NA to BS EN 1993-1-1 : 2005 + A1 : 2014 *UK National Annex to Eurocode 3 – Design of steel structures – General rules and rules for buildings*

BS EN 1993-1-3 : 2006 *Eurocode 3 – Design of steel structures – General rules – Supplementary rules for cold-formed members and sheeting*

NA to BS EN 1993-1-3 : 2006 *UK National Annex to Eurocode 3 – Design of steel structures – General rules – Supplementary rules for cold-formed members and sheeting*

BS EN 1990 : 2002 + A1 : 2005 *Eurocode – Basis of structural design*

NA to BS EN 1990 : 2002 + A1 : 2005 *UK National Annex for Eurocode – Basis of structural design*

BS EN 1995-1-1 : 2004 + A2 : 2014 *Eurocode 5 : Design of timber structures – General – Common rules and rules for buildings*

NA to BS EN 1995-1-1 : 2004 + A2 : 2014 *UK National Annex to Eurocode 5 : Design of timber structures – General – Common rules and rules for buildings*

BS EN 10270-3 : 2011 *Steel wire for mechanical springs – Stainless spring steel wire*

BS EN 10346 : 2015 *Continuously hot-dip coated steel flat products for cold forming – Technical delivery conditions*

BS EN 12326-1 : 2014 *Slate and stone for discontinuous roofing and external cladding – Specifications for slate and carbonate slate*

BS EN 13501-1 : 2018 *Fire classification of construction products and building elements – Classification using test data from reaction to fire tests*

PD 6693-1 : 2019 *Recommendations for the design of timber structures to Eurocode 5 : Design of timber structures – General – Common rules and rules for building*

Conditions of Certificate

Conditions

1. This Certificate:

- relates only to the product that is named and described on the front page
- is issued only to the company, firm, organisation or person named on the front page – no other company, firm, organisation or person may hold or claim that this Certificate has been issued to them
- is valid only within the UK
- has to be read, considered and used as a whole document – it may be misleading and will be incomplete to be selective
- is copyright of the BBA
- is subject to English Law.

2. Publications, documents, specifications, legislation, regulations, standards and the like referenced in this Certificate are those that were current and/or deemed relevant by the BBA at the date of issue or reissue of this Certificate.

3 This Certificate will be displayed on the BBA website, and the Certificate Holder is entitled to use the Certificate and Certificate logo, provided that the product and its manufacture and/or fabrication, including all related and relevant parts and processes thereof:

- are maintained at or above the levels which have been assessed and found to be satisfactory by the BBA
- continue to be checked as and when deemed appropriate by the BBA under arrangements that it will determine
- are reviewed by the BBA as and when it considers appropriate.

4. The BBA has used due skill, care and diligence in preparing this Certificate, but no warranty is provided.

5. In issuing this Certificate the BBA is not responsible and is excluded from any liability to any company, firm, organisation or person, for any matters arising directly or indirectly from:

- the presence or absence of any patent, intellectual property or similar rights subsisting in the product or any other product
- the right of the Certificate holder to manufacture, supply, install, maintain or market the product
- actual installations of the product, including their nature, design, methods, performance, workmanship and maintenance
- any works and constructions in which the product is installed, including their nature, design, methods, performance, workmanship and maintenance
- any loss or damage, including personal injury, howsoever caused by the product, including its manufacture, supply, installation, use, maintenance and removal
- any claims by the manufacturer relating to UKCA, UKNI or CE marking.

6. Any information relating to the manufacture, supply, installation, use, maintenance and removal of this product which is contained or referred to in this Certificate is the minimum required to be met when the product is manufactured, supplied, installed, used, maintained and removed. It does not purport in any way to restate the requirements of the Health and Safety at Work etc. Act 1974, or of any other statutory, common law or other duty which may exist at the date of issue or reissue of this Certificate; nor is conformity with such information to be taken as satisfying the requirements of the 1974 Act or of any statutory, common law or other duty of care.

British Board of Agrément

1st Floor, Building 3, Hatters Lane
Croxley Park, Watford
Herts WD18 8YG

©2024

tel: 01923 665300
clientservices@bbacerts.co.uk
www.bbacerts.co.uk